

FLIGHT & SERVICE MANUAL

GLASFLÜGEL CLUB LIBELLE 205

Issued October 1974

This Manual should always be carried in the Sailplane

It belongs to the Sailplane

CLUB LIBELLE 205 Works No.: 109

Registration: SP-4079

Manufacturer: GLASFLÜGEL, Ing. Eugen Hänle  
7311 Schlattstall, West Germany  
Tel. 07026/855

Owner: **Aeroklub Ziemi Pilskiej**



INDEX

Amendment to Manual.....	4
1 General Information.....	5
2 Operating Limits.....	9
2.1 Air Speeds.....	10
2.2 Airworthiness Category.....	12
2.3 Load Factors.....	12
2.4 Cloud Flying.....	13
2.5 Weights.....	13
2.6 C.G. Positions.....	13
2.7 Weak-links.....	13
2.8 Tire Pressure.....	14
2.9 Minimum Equipment.....	14
2.10 Aerobatics.....	15
3 Emergency.....	17
3.1 Spin Recovery.....	18
3.2 Aborted Take-off.....	18
3.3 Canopy Jettison.....	18
4 Normal Operation.....	19
4.1 Daily Inspection.....	20
4.2 Cockpit Lay-out.....	22
4.3 Cockpit check before take-off.....	25
4.4 Take-off.....	25
4.5 Free Flight.....	26
4.6 Slow Speed Flight, Stall.....	27
4.7 High Speed Flight.....	27
4.8 Cloud Flying.....	28
4.9 Aerobatics.....	28
4.10 Landing.....	30
4.11 Tie-down, Ground-handling.....	30
5 Rigging & De-rigging.....	31
5.1 Rigging.....	32
5.2 De-rigging.....	32
6 Maintenance.....	33
6.1 Mandatory Maintenance.....	34
6.2 Regular Maintenance.....	35
6.3 Maintenance of Surface Finish.....	41
6.4 Damage.....	41
6.5 Maintenance Instructions TOST.....	42
7 Annex.....	43
7.1 C.G. Determination.....	44
7.2 Performance Data.....	46
7.3 Equipment List.....	50

Amendments to Manual:

No.	Description	Page	Date	Signature
1	E 51, E 52, E 53	E 51 E 52 E 53	4-00-2023	
2	42a, 42b	42a 42b		

1  
GENERAL INFORMATION

## 1 GENERAL INFORMATION

The "CLUB LIBELLE 205" is a single seat 15 m sailplane in Glasflügel all fibreglass construction.

### Wing

The two-piece double trapezoidal wing is cantilever. It is constructed as a GRP-Foam-Sandwich shell with spar caps of parallel glass fibres, extruded by a method developed by Hütter and Hänle, and sheer webs of reinforced plastic balsa sandwich.

### FUSELAGE

The fuselage is slimmed out behind the wing, and the clam-shell canopy is hinged at the back. The fuselage shell is of GRP without a sandwich filler, and therefore capable of large energy absorption. The fuselage shell is supported by GRP profile frames. The pilot is seated in a semi-reclining position. The landing gear is sprung, and non-retractable. Nose- and CG-releases are installed.

### HORIZONTAL TAILPLANE

The horizontal tailplane has a horizontal stabilizer and elevators, and the trim spring is activated by a button on the control column. The stabilizer is of GRP foam sandwich.

### RUDDER

The fin is constructed of GRP, similarly to the fuselage, without foam. The rudder is activated by internal drive.

### COCKPIT INTERIOR

The control column is of the anti-P.I.O. (pilot induced oscillation) type, and is insensitive to gusts. Back-rest and rudder pedals are adjustable in flight. A seat cushion with inflatable knee supports is standard equipment.

The ventilation air is available from the fuselage inlet in the nose, and through the sliding window in the canopy.

### TECHNICAL DATA

Span	b = 15 m (49.2 ft)
Wing area	S = 9.80 m <sup>2</sup> (105,5 sq. ft)
Aspect ratio	b <sup>2</sup> /S = 23
Fuselage length	l = 6.40 m (21 ft)

#### Control Deflections:

Elevator: up and down	17.5° ± 1.5°
Rudder: both sides	25° ± 2°
Aileron: up	22° ± 2°
down	10° ± 2°
Airbrakes:	60° - 5°

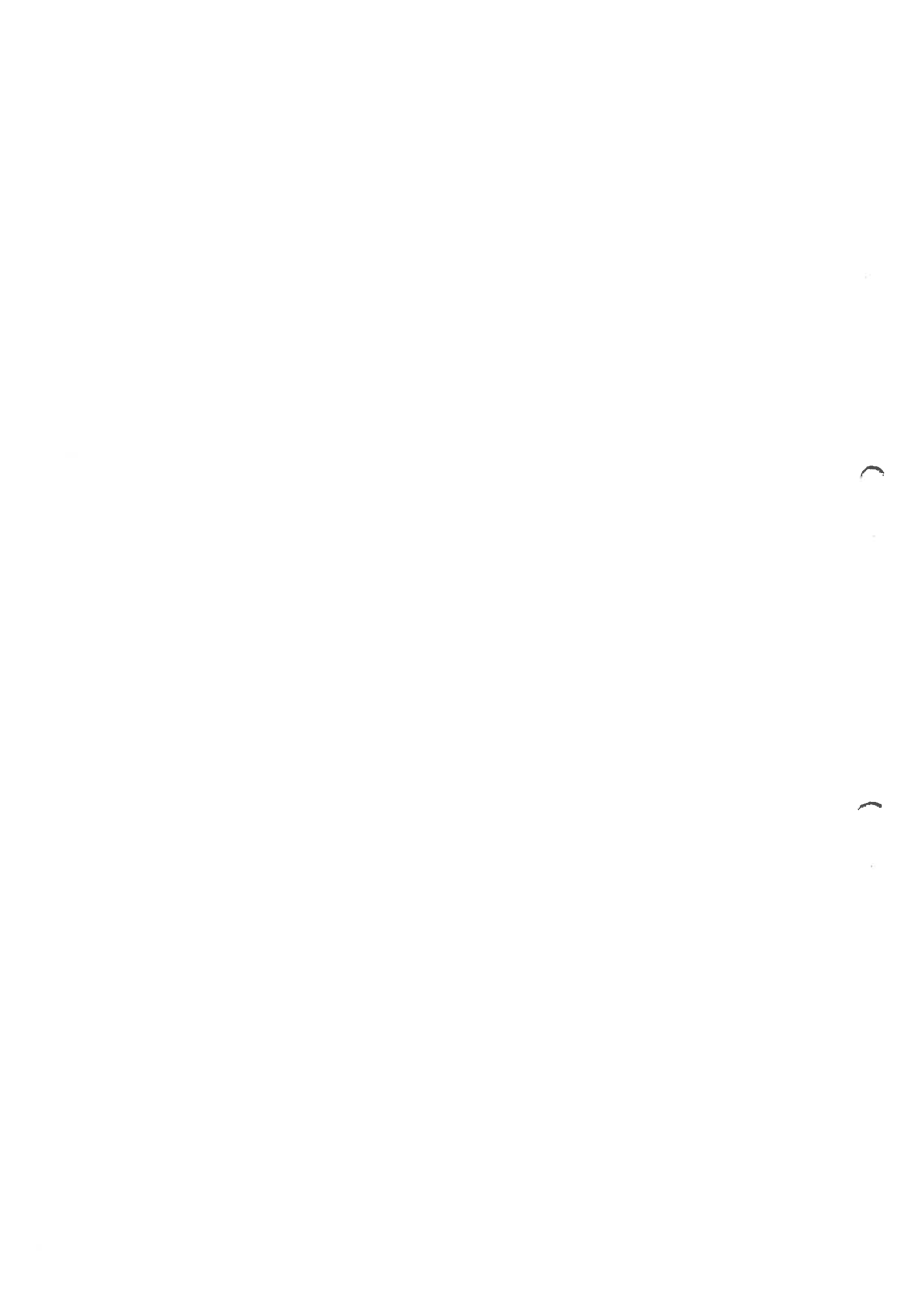

2  
OPERATING LIMITS

2 OPERATING LIMITS

2.1 AIR SPEEDS (IAS)

Maximum permissible speed.....	$V_{NE}$	= 200 km/h	( 108 kt
Manoeuvring speed.....	$V_A$	= 150 km/h	( 81 kt
Maximum permissible speed on aerotow.....	$V_T$	= 135 km/h	( 73 kt
Maximum winch and auto speed.....	$V_W$	= 120 km/h	( 65 kt

Please note that at increasing altitudes the true air speed is higher than the indicated air speed. This has no influence on the strength or load factors of the sailplane, however, for reason of flutter safety, the following indicated air speeds should not be exceeded.

Height		IAS	
m	ft	km/h	kts
0	0	200	108
1000	3000	200	108
2000	7000	200	108
3000	10000	200	108
4000	13000	196	106
5000	16000	186	100
6000	20000	176	95
7000	23000	166	90
8000	26000	157	85
9000	30000	148	80
10000	33000	139	75
12000	40000	122	65

Air speed indicator (AIS) error  
(at MSL)

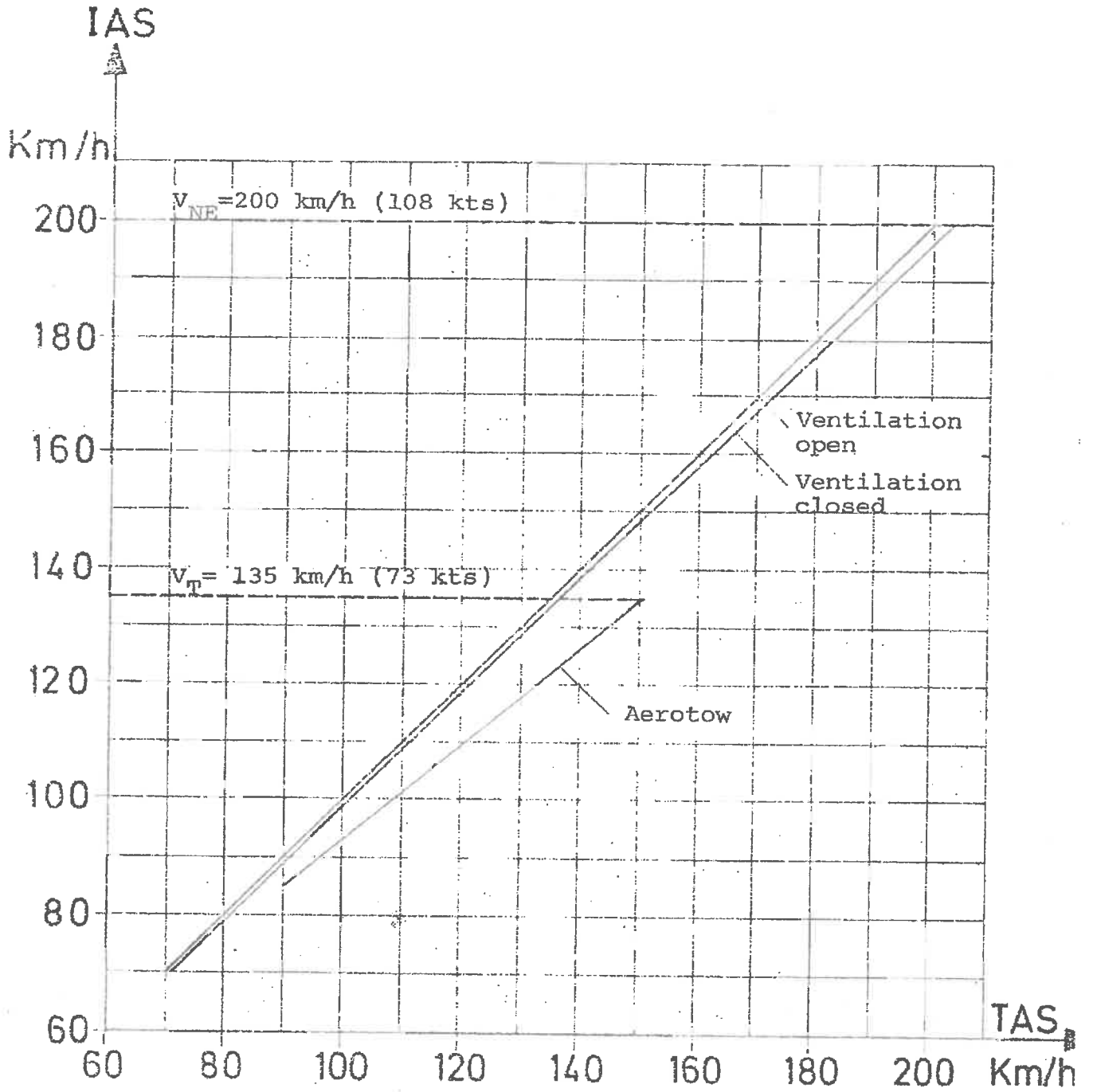

## 2.2 AIRWORTHINESS CATEGORY

N, Normal Category (LFS 1966)

U, Utility (OSTIV 1971)

Based on the airworthiness requirements LFS and OSTIV, full control movements can be used up to manoeuvring speed of  $V_A = 150$  km/h (81 kts).

At speeds above 150 km/h (81 kts) it is possible to overstress the sailplane structurally, and at maximum permissible speed the  $V_{NE} = 200$  km/h (108 kts), only a maximum of 1/3rd of the full control deflection is permissible. For the elevator, the permissible deflection at  $V_{NE}$  is considerably smaller and is related to the permissible pull-out load factor.

This sailplane can be flown safely under gusty conditions up to  $V_{NE} = 200$  km/h (108 kts). However, in very strong turbulence as encountered in wave rotors or in thunder clouds (turbulence above 10 m/sec = 30 fps) a speed of 150 km/h (81 kts) should not be exceeded.

## 2.3 LOAD FACTORS

The following load factors should not be exceeded.

at 150 km/h (81 kts)	+5.3/-2.65	Airbrakes
200 km/h (108 kts)	+4.0/-1.5	closed
150 km/h (81 kts)	+3.5/-1.7	Airbrakes
200 km/h (108 kts)	+2.6/-1.0	open

The safety factor (or reserve factor) is then  $j = 1.5$

2.4 ~~..... approved with corresponding equipment.~~

2.5 WEIGHTS

Maximum permissible weight (mass).....350 kg (772 lbs)  
Maximum permissible weight (mass)  
of non-lift carrying parts.....225 kg (496 lbs)

2.6 CENTRE OF GRAVITY (CG) POSITIONS

The permissible CG positions (flight) are at 256 mm (10.1 in.) and 380 mm (15 in.) behind reference point (corresponds to 30% - 48% mean cord).

Pilots, including parachutes weighing below 65 kg (143 lb) must carry lead cushion, so that the minimum loading is equalled. This cushion is available from the Fa. Glasflügel.

Weighing date					
Carried out by					
Empty weight					
Equipment list date					
CG position behind reference					
Minimum loading in cockpit					
Maximum loading in cockpit					

2.7 WEAK-LINKS

Winch tow                    5000 N (1100 lbs)  
Aerotow                    5000 N (1100 lbs)

2.8 TYRE PRESSURE (absolute)

in main wheel	3.0 bar (44 psi)
in tail wheel	2.5 bar (36 psi)

2.9 MINIMUM EQUIPMENT

Air speed indicator with range from minimum 50 km/h (27 kts) to 250 km/h (135 kts) with following colour coding:

Green arc.....	80 - 150 km/h (43-81 kts)
Yellow arc.....	150 - 200 km/h (81-108 kts)
Red mark.....	at 200 km/h (108 kts)

4-piece safety harness

Manual parachute, otherwise back cushion (compressed approx. 10 cm thick)

Placard with operating limits

Placard "Cockpit check before take-off"

Flight and Service Manual

For CLOUD FLYING in addition to the minimum equipment:

Compass

Altimeter

Turn & Bank Indicator

VHF Transceiver

Experience so far, has shown that the installed Air Speed Indicator pitot is suitable for cloud flying.

For Aerobatics, in addition to minimum equipment:

Altimeter

The minimum equipment items must be of an approved type. An equipment list is printed under 7.3.

## 2.10 AEROBATICS

The "Club Libelle 205" with corresponding equipment is approved for the following aerobatic manoeuvres:

Inside loops

Spins

Stall turns

Lazy eights

It is recommended to install a recording "g" meter in addition to the equipment listed on page 14.

2

3

3

ÉMERGENCY

### 3. EMERGENCY

#### 3.1 SPIN RECOVERY

Should the sailplane at medium to rear C.G. positions enter a spin, the back pressure on the control column should be released (control column moved in forward direction) and opposite rudder applied to recover. The release of the back pressure on the control column is necessary as the sailplane may otherwise change into a spin of opposite rotation.

#### 3.2 ABORTED TAKE-OFF

Take-off in medium to high grass should not be attempted on winch and aerotow. Should a wing catch in grass, release at once without delay to prevent groundloop. When using above average size winch cable drag chutes combined with an initial shallow climb, the drag chute may open in the early take-off phase. In this case, release the cable and proceed with the landing straight ahead.

After emergency release at low height a minimum speed of 90 km/h (49 kts) in straight and level flight should be maintained, the speed should be correspondingly higher in a turn, depending on angle of bank. This prevents the sailplane from unintentionally and unnoticeably entering a stalled condition. Should one notice a light shudder and vibration in level flight, then the sailplane is stalled, in spite of A.S.I. readings of 65 - 85 km/h (35 - 46 kts), and the control column should be released and eased forward.

#### 3.3 CANOPY JETTISON

Pull red handle und push canopy upwards.



#### 4. NORMAL OPERATION

##### 4.1 DAILY INSPECTION

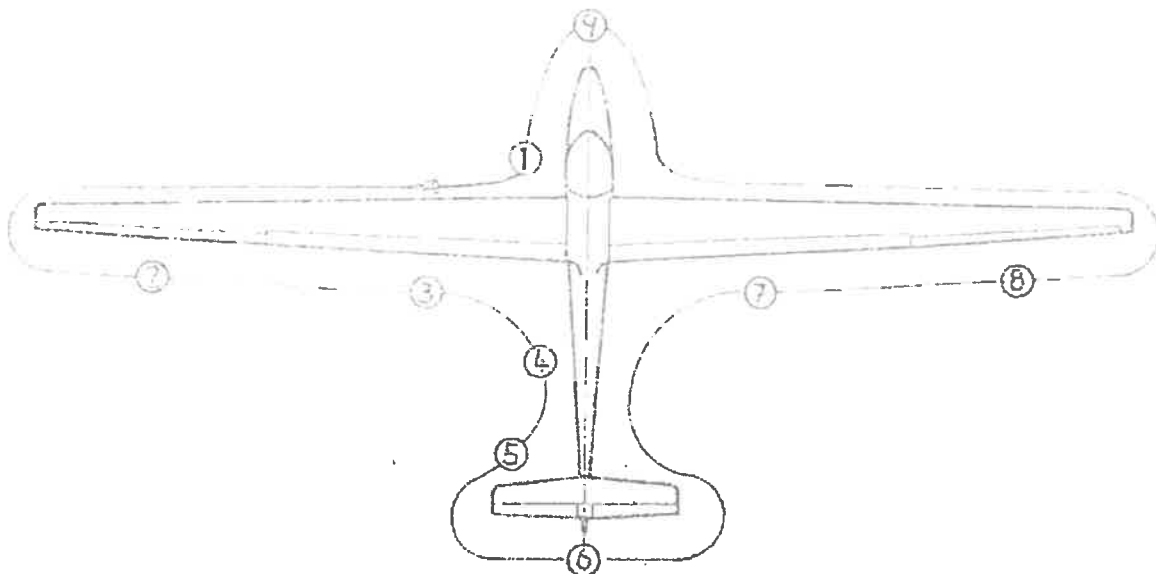

When inspecting the sailplane check for cracks in the surface finish, blisters or uneven surface, and if in doubt check with authorized, specialized personnel.

- 1.a) Open canopy, check if the central wing pin is installed.
  - b) Visual cockpit control inspection.
  - c) Remove foreign material from fuselage.
  - d) Check tire pressure in main wheel (3.0 bar = 44 PSI).
  - e) Check function of winch release and condition of the two cable deflectors.
2. Check ailerons for free and full movement.
- 3.a) Check airbrakes for free movement and clean fit.
  - b) Check aileron and airbrake trailing edges for damage. Sharply rotate by hand on trailing edge to check for unusually large play in the system.

4. Check if the holes for the static pressure on the fuselage shell are clear.
- 5.a) Check if the front stabilizer attachment bolt is engaged.
  - b) Fit Althaus Venturi and check line (when blowing into the venturi, the connected variometer registers climb).
  - c) Check tire pressure in the tail wheel (2,5 bar= 36 PSI).
- 6.a) Check elevator and rudder for free and full movement.
  - b) Check elevator and rudder for damage, sharply rotate by hand on trailing edge to check for unusually large play in the system.
7. See under 3.
8. See under 2.
- 9.a) Check the function of the aerotow release.
  - b) Check for blocked pitot. Blow into pitot, ASI registers.

After a hard landing, or excessively high g-loads, the sailplane should be carefully examined for any indications of damage. Disassemble the sailplane and check the surface finish for cracks. Look for white areas (that may indicate delamination) in the wing spar root-ends, wing root rib fittings, landing gear attachments, tail fittings, and all areas of concentrated loads. Also inspect the central wing pin and tail attachments for distortion. If damage is found, the sailplane should be grounded until all repairs have been completed.

#### 4.2 COCKPIT LAY - OUT

##### 1. Instrument panel

The instrument panel can be withdrawn after removing two bolts.

##### 2. Control column:

The elevator is moved by a parallelogram system which prevents unintentional movements induced by gusts.

The following are mounted on the control column:

- a) Radio button: press-to-transmit
- b) Spring trim button: depress with the little finger and release in any selected control column position.
- c) Trim lever: can be adjusted manually when trim button is depressed.

Forward rotation = nose heavy.

Rearward rotation = tail heavy.

##### 3. Wheel brake:

Hand grip on airbrake operating lever.

##### 4. Tow-release:

The yellow grip on the left side of the instrument panel activates both releases.

##### 5. Airbrakes:

Pull blue lever on the left cockpit wall = open.

Push lever forward and lock = close.

##### 6. Canopy lock:

Push red grip forward = close.

Pull red grip and push canopy upwards = open and jettison.

7. Backrest:  
Adjustment is possible during flight. Release black notch on right cockpit wall. Release weight on backrest and pull: Backrest moves forward.
8. Rudder pedal adjustment:  
By pulling the black grip under the instrument panel the pedal adjustment is un-locked.  
Forward adjustment: Pull black grip while pushing pedals forward with heels. Release grip and let pedals lock into position.  
Back adjustment: Pull pedals back with black grip.
9. Cockpit ventilation:  
Pull blue knob on instrument panel: Ventilation closed. In addition, the sliding window in the lefthand side of the canopy may be opened.
10. Knee support cushion:  
Adjustable by two air pumps.
11. Placard in cockpit:

<p>PRE-FLIGHT COCKPIT CHECK</p> <p>Parachute correctly fitted?</p> <p>Safety harness correctly and firmly adjusted?</p> <p>Backrest and pedals locked in comfortable position?</p> <p>All controls and instruments within easy reach?</p> <p>Airbrakes locked?</p> <p>Control check?</p> <p>Free, full and correct movement of controls?</p> <p>Correct trim position?</p> <p>Canopy locked?</p> <p>Release check?</p> <p>Towline on correct release - correct weak-link?</p>
---

GLASFLÜGEL "CLUB LIBELLE 205"

Operating Limits

Maximum permissible speed	$V_{NE} = 200$ km/h (108 kts)
Manoeuvring speed	$V_A = 150$ km/h (81 kts)
Max. permissible speed on Aerotow	$V_T = 135$ km/h (73 kts)
Max. speed on Auto and Winch Tow	$V_W = 120$ km/h (65 kts)
Max. permissible A.U.W.	350 kg (772 lbs)
Max. Weight of non-lift carrying parts	225 kg (496 lbs)
Loading on seat	65 - 110 kg (143-243 lb)

Wheel brake

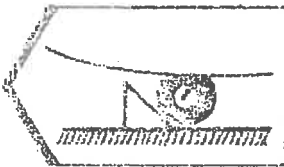

Tow release

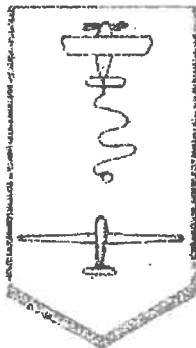

Backrest

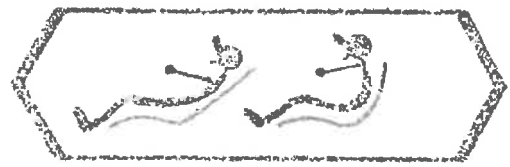

back

forward

Rudder pedal adjustment



Airbrakes



open

closed

Ventilation



pull: closed

Canopy jettison



#### 4.3 COCKPIT CHECK BEFORE TAKE - OFF

See placard in cockpit

#### 4.4 TAKE - OFF

Aerotow

For aerotow textile ropes of 35-60 m (115-200 ft) length were tested. Tow only from nose release. When commencing the take-off run use wheel brake slightly to prevent rolling over tow rope.

Depending on loading in the cockpit, the trim setting before should be "normal" to "nose heavy". After lift-off at approx. 70-80 km/h (38-43 kts), the trim can be adjusted so that no elevator load is noticeable.

The normal towing speed is approx. 90-100 km/h (49-54 kts), max. 135 km/h (73 kts) IAS. It is possible that the ASI will show a lower reading caused by towrope interference (see page 9).

Should the sailplane be unintentionally displaced laterally, the wings should remain level while bringing the sailplane back into position by rudder. Should the sailplane be displaced vertically into a too high tow position during high tow, with danger of over-shooting the tow aircraft, the airbrakes should be opened.

Pull release right <sup>H</sup>rough and repeat, ensure that the cable has released before turning away.

#### Winch tow

Winch tow should only be attempted on C.G. release. Before take-off, the trim is set to normal for forward and medium C.G. positions, and nose heavy for medium to rear C.G. positions. When commencing the take-off run, use wheel brake slightly to prevent rolling over towrope. This sailplane does not have the tendency to enter into a steep climb after take-off, and therefore, depending on the trim setting, only small correction with the elevator is necessary to prevent a very steep climb in the early take-off phase.

After a safety height of approx. 50 m (150 ft) is reached, the sailplane can be brought into a steeper climb by more back pressure on the control column. If too much back pressure is applied and porpoising occurs (elevator stall), release some of the back pressure.

The normal towing speed is approx. 100 km/h (54 kts), max. 120 km/h (65 kts).

#### 4.5 FREE FLIGHT

At a safe height experiment with the airbrakes and note loss of height at different speeds.

This sailplane has very good balanced flight characteristics and controls. Rate of turn from  $45^{\circ}$  to  $45^{\circ}$  bank at 1.4 x stalling speed are possible in 3 to 3.5 secs.

On the other hand, it is possible to fly "hands off" in straight and level- or circling flight without the sailplane changing it's attitude or speed. All control movements require only very low operating forces.

#### 4.6 SLOW SPEED FLIGHT, STALL

For familiarization with this sailplane, we recommend to do stalling tests from a straight and level flight, and from banked flight (approx. 45° bank) at safe heights.

The following stalling speeds were measured:

A.U.W	300 kg (661 lbs)	350 kg (772 lbs)
Stalling speed		
with closed airbrakes	65 km/h (35 kts)	70 km/h (38
with open airbrakes	61 km/h (33 kts)	65 km/h ( 3

Immediately when the stalled condition is reached, a stall warning in the form of a light shudder and vibration occurs. If the control column is slowly pulled back further, the ASI reading may momentarily increase again. With the control column all the way back this sailplane will usually drop a wing. The back pressure on the control column should then immediately be released. If the airbrakes are extended, the loss of height after wing drop may be approx. 50 m (150 ft).

#### 4.7 HIGH SPEED FLIGHT

During high speed flight in gusty conditions with ASI in yellow arc, avoid large and sudden elevator movements. The necessary control column travel, in particular at rear C.G. positions, from the stalling speed to the maximum speed is relatively small, however, any speed change will be noticed by a change in the control forces.

The airbrakes can be opened up to  $V_{NE} = 200$  km/h (108 kts). The safety harness should be tight. The closing of the airbrakes should, owing to the steep flight path, only be attempted under 150 km/h (81 kts).

Should the ASI readings listed on page 10 be unintentionally exceeded, the airbrakes should be opened without delay. Also ensure that you are harnessed firmly and that the control column is not unintentionally moved while operating the airbrakes. Take note that the sailplane with open airbrakes must be pulled out of dives with lesser "G" loads compared to closed airbrakes (see page 12 pull-out load factors).

If the airbrakes are opened during higher speeds (above 150 km/h = 81 kts) they should always be opened quickly and fully. In particular, the operating lever should not be held near the locking position (slightly open).

#### 4.8 CLOUD FLYING

The spin should not be used as a safety escape as the sailplane may change over into a spiral dive. It is rather recommended to open the airbrakes fully at IAS of 130 km/h (70 kts) and load factors above 2 "G". At speeds above 150 km/h (81 kts) the airbrakes should not be closed, as this sailplane, owing to its very steep glide path, may exceed the max. permissible speed.

#### 4.9 AEROBATICS

Inside loops:

Speeds for entry not under 170 km/h (92 kts).

Recommended 180 km/h (97 kts).

Load factor for entry + 3.0 to 3.5 g

Speed for recovery 160 km/h (86 kts).

Spins:

Spins are only possible with the CG near the aft limit. At medium forward CG positions this sailplane may change from a spin to a spiral dive. This should be terminated at once by neutralizing all controls and careful pull-out and recovery, if the airbrakes are closed.

Spins with fully airbrakes are possible. Should this sailplane change over into a spiral dive, the speed is automatically limited to 140 km/h (96 kts).

Speed for entry: 70 km/h (38 kts)

Speed for recovery:

with closed airbrakes 150 to 170 km/h(81-92kts)

with open airbrakes 115 to 130 km/h(62-70kts)

Recovery is by relaxing the control column forward and applying opposite rudder.

Stall turn:

Speed for entry not under 180 km/h (97 kts). Load factor during entry and recovery + 3 g.

Speed during recovery 180 km/h (97 kts).

After the entry, during vertical climb, at approx. 120 km/h (65 kts) IAS full rudder is applied.

Lazy Eight:

Speed for entry approx. 180 km/h (97 kts) followed by a pull-up into 30-45° and at 120 km/h (65 kts) initiate turn. Speed for recovery 180 km/h (97 kts).

Load factor + 3.5 g.

During steep turns, the following speeds, depending on load factors and angle of bank, should not be less than:

Load factors	Angle of bank	Speed
+ 2.0	60 °	105 km/h (57 kts)
+ 2.5	65 °	120 km/h (65 kts)
+ 3.0	70 °	130 km/h (70 kts)
+ 3.5	73 °	145 km/h (78 kts)

#### 4.10 LANDING

The rotating trailing edge airbrakes are a very effective landing device and make possible steep, as well as relatively slow approaches. They do not increase or decrease lift, if this sailplane, depending on A.U.W. is flown down to a minimum speed of 70-75 km/h (38-40 kts). Below this speeds the brakes should not be closed.

For very steep approaches (i. e. in strong ground turbulence) the airbrakes are opened fully and the glide angle is only controlled with the elevator. Excess height can be absorbed by a steeper approach with relatively little speed increase.

During normal approaches the brakes can be opened and closed according to need, and the speed should be a minimum of 70 km/h (38 kts) (at 300 kg = 660 lbs A.U.W. approx.). Shortly before touch-down, the airbrakes should always be fully opened. Side slipping is not necessary for landing.

Just Before Round Out (REAR PART) *[Signature]*

*CAUTION WITH THIS  
IF GOES AGAINST WHAT WE TRY TO INSTRUCT FOR OTHER GUIDES*

#### 4.11 TIE-DOWN, GROUND - HANDLING

This sailplane should not be parked in the open with opened canopy, as this may act as a magnifying mirror and depending on direction of sun-radiation may set fire to the seat cushion.

When pulling this sailplane behind a car, a tail-dolly should be used, so that the tailplane attachment is not unnecessarily stressed by vibration of the tailplane.

When this sailplane is ground-handled, it should not be pushed on the wingtips, but rather closer to the fuselage.



## 5. RIGGING & DE-RIGGING

### 5.1 RIGGING

- 1) Clean and grease bolts and bearings.
- 2) With the airbrake hand lever in the medium position, and the airbrakes on the wings half opened, the left (port) wing is inserted first. Take note that the bellcranks on the root rib engage into the opposing sockets on the fuselage.
- 3) Insert right (stbd) wing and pull together with rigging tool. As with the left (port) wing, ensure correct engagement of control linkage.
- 4) Insert central wing pin.
- 5) Check aileron and airbrake controls.
- 6) Fit horizontal tailplane and push leading edge rigging pin home. Check that the elevator drive pins engage into the elevator (move elevators).

### 5.2 DE-RIGGING

- 1) Pull leading edge rigging pin off the horizontal tailplane and remove tailplane.
- 2) Lift wingtips and remove central wing pin.
- 3) Separate wings with rigging tool and remove wings.

6  
MAINTENANCE

6. MAINTENANCE

6.1 MANDATORY MAINTENANCE

After every 100 operating hours and during every yearly inspection, the rudder cable should be checked in the area of the S-shaped tube of the pedal in both, front and rear pedal adjusting positions. The cables should be replaced if wear, twist, corrosion or other damage can be detected. A wear up to 40% of the single outer wires is still permissible.

**Material:** Steel wire cable B 3.2 LN 9389 of stainless steel or steel wire cable B 3.2 LN 9374 of galvanized carbon steel, in conjunction with Nicopress clamps No. 28-3-M and tool No. 51-M-850 or 63-V-XPM or 64-CGMP, whereby always the M-groove should be used.

Only the correct tools should be used in conjunction with these clamps. The works and inspection instructions corresponding to the tool should be adhered to.

**Supplier:**

GLASFLÜGEL Ing. Eugen Hänle, 7311 Schlattstall  
(clamps and cable)

R. Lindemann, 2050 Hamburg 80, Osterrade 12  
(clamps and tools)

## 6.2 REGULAR MAINTENANCE

In the framework of the yearly inspection, the following maintenance should be carried out. The controls (see GA drawing Page 38-40) are accessible as follows:

Drives within the wings through inspection holes on the under surface of the aileron drive, on the opened airbrakes and on the root rib.

Drives in the fuselage after removal of the inspection cover on the fuselage underside, after removal of the two hand-hole covers behind the backrest, and after removing the seat tray.

Elevator drive after the removal of the tailplane.

Rudder drive after removal of rudder.

After cleaning the whole aircraft, proceed as follows:

Check GRP outside surface condition for holes, tears, cracks, paint cracks, indents, delamination. On damage to outer layers of sandwich, the inner layers should also be checked. Call on the help of an experienced person.

Check all metal parts for corrosion, and if necessary, clean up and preserve again (fittings, pushrods and levers are protected with the single component primer B 1742 from Lackfabrik Bäder and preserved with nitro lacquer).

In control runs with excessive friction, the bearings and joints should be cleaned and lubricated. The permissible friction in the elevator controls can be checked in flight:

From a trimming speed of 120 km/h (65 kts) and freed controls, the sailplane should be returning within  $\pm 15$  km/h (8 kts) of the original trimmed speed.

Bearings and joints with excessive radial play should be replaced. The automatic connections for ailerons and airbrakes between wing and fuselage can be adjusted free of play on the adjusting bolts of the four socket fittings.

The play in the airbrake circuit may be 3 mm (c.1/8") measured on the T.E. of the airbrakes.

All fittings which are attached to GRP should be checked for firm adhesion.

Check the condition of the GRP near the fittings for cracks and white areas of delamination.

Landing gear: clean brake drum, check brake linings and if necessary renew, check side play of wheel hub, check and adjust bowden cable or brake lever.

Check static and pitot inlets, as well as lines, and 4-way quick connector for free flow and leaks.

Check control deflections (page 7) and function of the control system and releases on the rigged aircraft.

A gap of 3 mm (about 1/8") minimum should be allowed between airbrakes and ailerons.

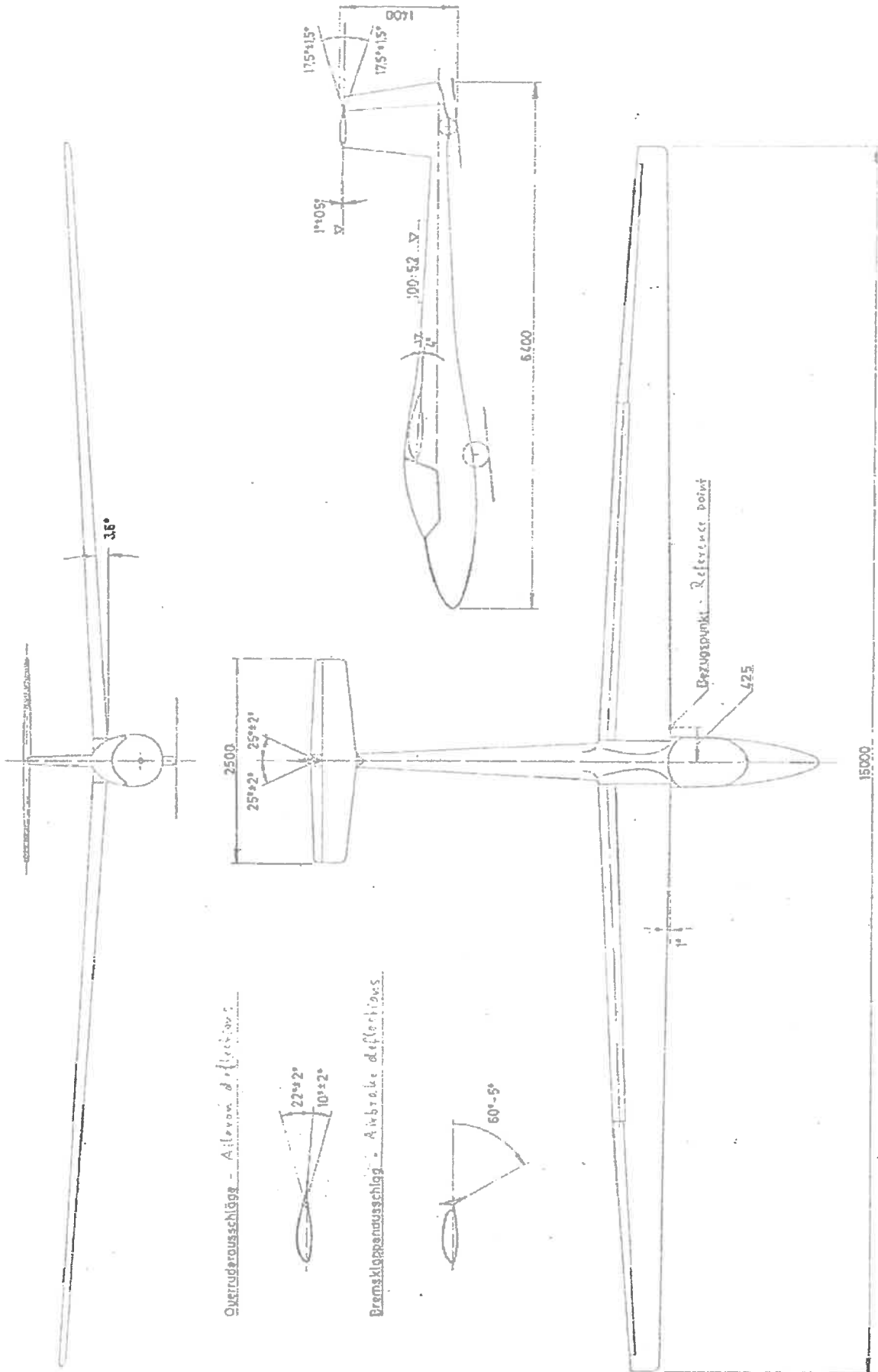

AILERON LINKAGE ADJUSTMENT POINTS

- ① } RED LENGTHS
- ② }
- ③ }

④ LINKUP BEARING CLEARANCE

NOTES: THE LENGTHS OF LINKS ① & ② WILL AFFECT THE OVERCENTRE ACTION AT POINT 'A'

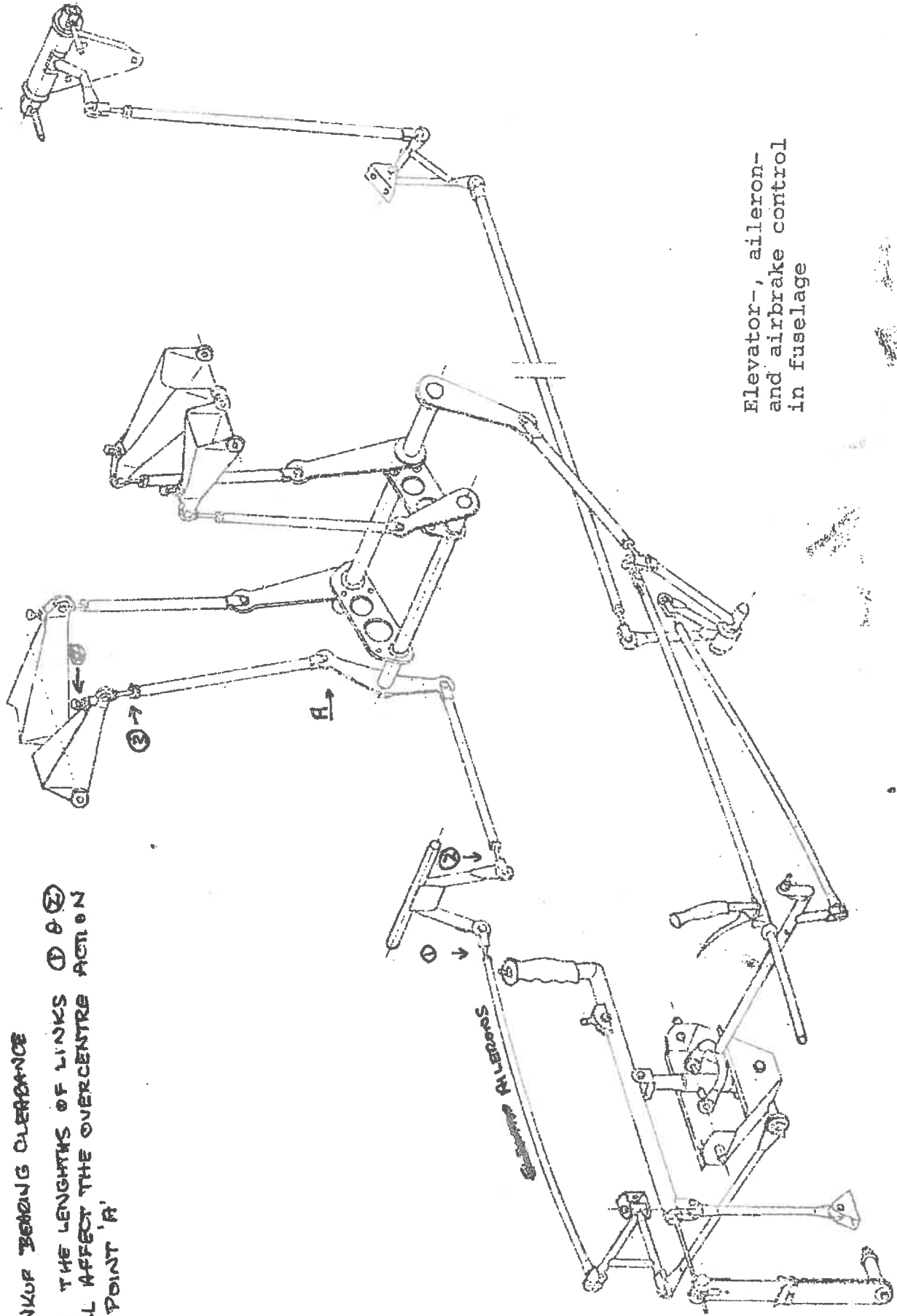

Elevator, aileron- and airbrake control in fuselage

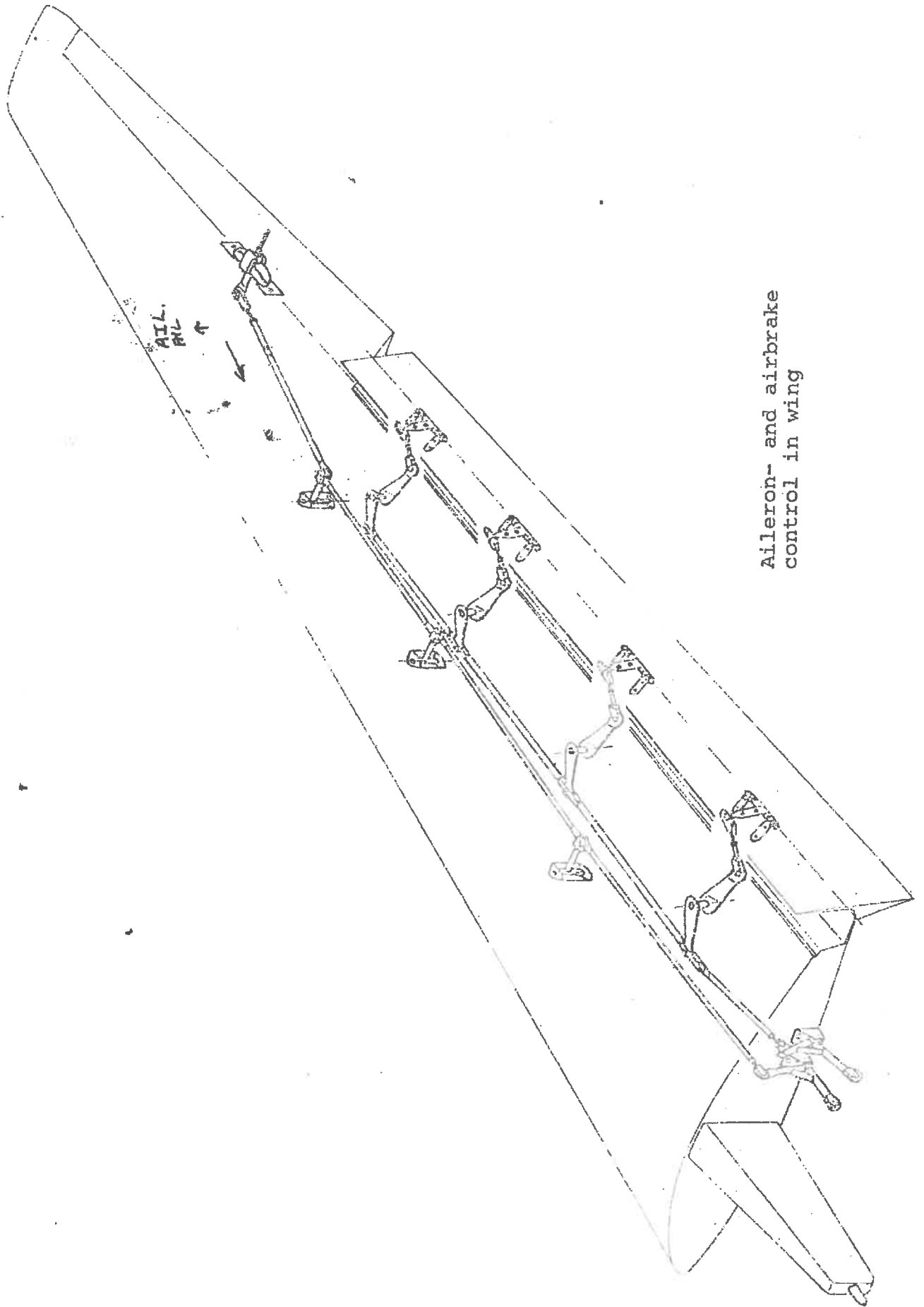

Aileron- and airbrake control in wing

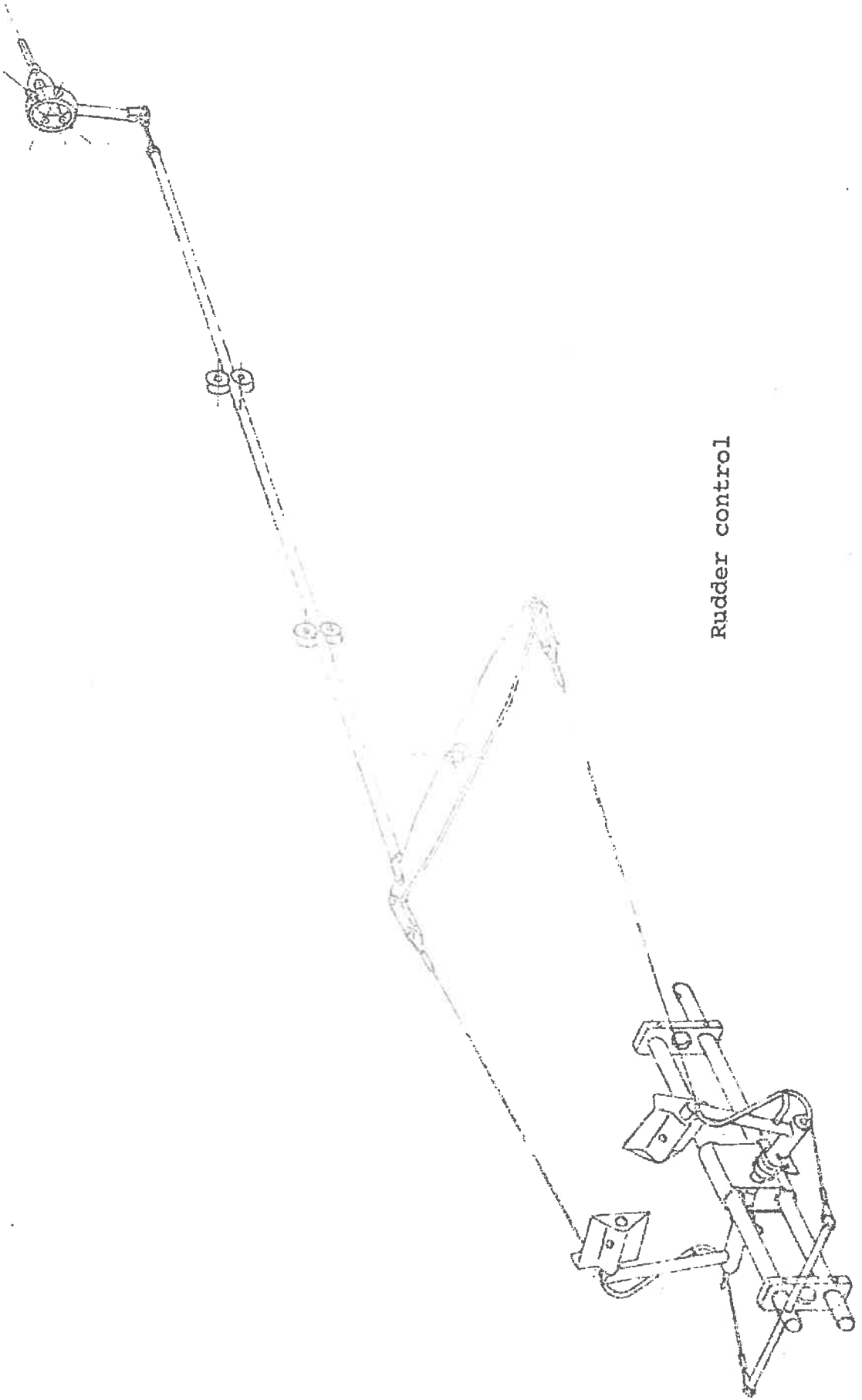

### 6.3 MAINTENANCE OF SURFACE FINISH

Wash surface only with clear water, sponge and chamois.

Never use petrol, alcohol or thinners.

Soap additives in water should not be used too often.

Polish as often as you wish, but take care not to heat up the surface when using a polishing machine, as otherwise the surface quality will suffer.

Exposure to moisture should be avoided, as with all other sailplanes.

Protect from intensive sun radiation (heat) and unnecessary continuous load.

Please note that the surface of all parts which are exposed to sun radiation must be coloured white. Colours other than white will increase the heat build-up in the GRP so that insufficient strength would be the result.

### 6.4 DAMAGE

Before each take-off, and in particular after lengthy storage, an inspection should be carried out.

Check for small changes such as holes, blisters or unevenness in the surface. This may be the signal that something is wrong.

It is the best to consult an experienced person in GRP if stressed parts are in question. Better still, to make available photographs of the damage to a specialized representative of the manufacturer, who will advise the correct procedure, therefore saving unnecessary repair attempts.

GRP parts are neither expensive nor difficult to repair, but have a different technology from sailplanes of other materials.

Scratches and small cracks in the surfaces can be repaired by the owner.

After studying the Plastic Plane Patch Primer Repair Manual, these should present no great problems.

Small repair kits with all necessary materials for minor repairs are available from GLASFLÜGEL.

Major repairs may only be carried out by the manufacturer or his authorized representatives.

- 6.5 Instructions from Firma TOST concerning the maintenance of the main wheel and tow releases should be noted.



7. ANNEX

7.1 C.G. DETERMINATION

To establish the C.G., the sailplane is rigged with closed canopy. The tailwheel is placed on a scale in such a way that the rear fuselage cone is angled 3° down towards the rear (wedge pattern 100 : 5.2 atop rear fuselage cone, and spirit level).

The tail weight  $m_2$  is now established with the wings horizontal. The distances a and b are now measured with the help of plumbs, or are referred to in the last weight record. The empty weight of the sailplane is established through weighing.

CG empty: 
$$X_{\text{empty}} = \frac{m_2 \text{ empty} \cdot b}{m_{\text{empty}}} + a$$

The aircraft is unoccupied without parachute, but with the total fixed equipment included.

CG in flight: 
$$X_{\text{flight}} = \frac{m_2 \text{ flight} \cdot b}{m_{\text{empty}} + m_{\text{loading}}} + a$$

The aircraft is weighed with loading (pilot, parachute and total removeable equipment such as barograph, cushion, camera etc.). Take note to correctly adjust pedals and backrest.

reference

wing root leading edge  
at  $y = 425 \text{ mm (16.7 in)}$   
out from fuselage  
centre line

horizontal  
reference

wedge pattern 100:5.2  
atop fuselage cone  
and spirit level

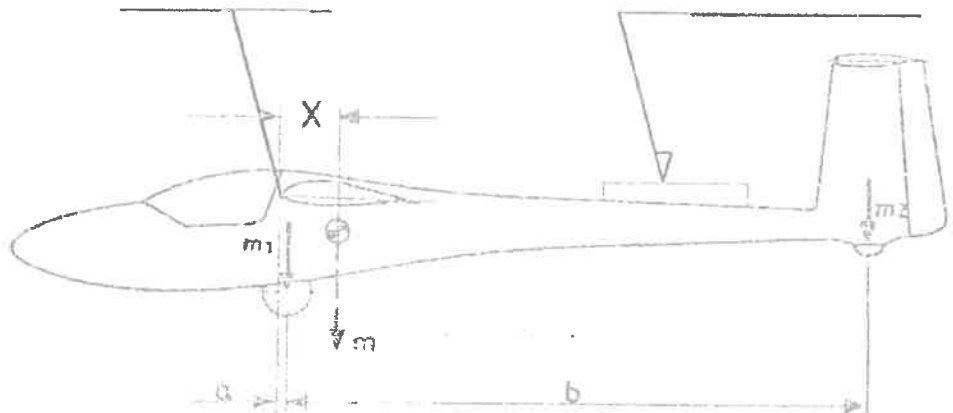

The C.G. of the empty sailplane, with normal loading between 65 - 110 kg (143 - 243 lbs) should fall into the shaded area of the following diagram. Should this sailplane in particular cases be trimmed so that the C.G. falls above or below the shaded areas, and the maximum loading is smaller than 110 kg (243 lbs) or the minimum loading is larger than 65 kg (143 lbs), these loadings should be placarded in the cockpit (i. e. minimum loading on seat 80 kg (176 lbs)). For this, an extended trim diagram should be requested from Glasflügel. This modification should be certified into the operating documents by an approved inspector.

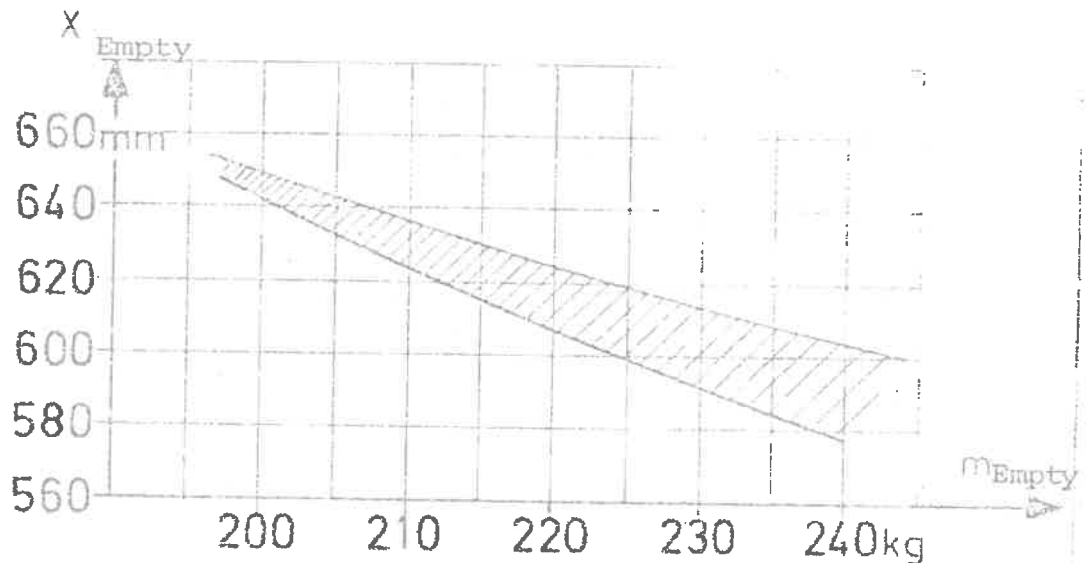

The establishment of the empty C.G. is necessary after installation of additional equipment, after repairs, new surface finishing or other modifications, which may change the weights of the sailplane. Weights and C.G. should be entered into the operating documents by an approved inspector with reference to the equipment list. For high performance and competition flying it is recommended to establish the flight C.G. for the individual pilots, as the performance of the sailplane deteriorates outside the optimum C.G. range. The optimum C.G. range is approx. between 335 and 380 mm (13.2 and 15.0 in) behind reference point.

7.2 PERFORMANCE DATA:

The following performance data was calculated for the "CLUB LIBELLE 205":

A.U.W. Total mass	300 kg (661 lbs)	330 kg (728 lbs)
best glide	35 at 83 km/h (45 kts)	35 at 87 km/h(47 kt
min. sink	0.59 m/sec at 70 km/h (1.94 FPS at 38 kts)	0.62/sec at 74 km/h (2.03 FPS at 40 kts)

Polar (in reference to NN)

Glide angle $\epsilon$	m = 300 kg		m = 330 kg	
	V km/h	W m/s	V km/h	W m/s
30.8	67	0.60	70	0.63
32.6	69	0.59	72	0.62
33.5	72	0.59	75	0.62
34.0	74	0.60	78	0.63
34.5	77	0.62	80	0.65
34.8	80	0.63	83	0.66
34.9	83	0.66	87	0.69
34.9	86	0.69	90	0.72
34.6	90	0.72	94	0.75
34.2	94	0.76	98	0.80
33.5	98	0.81	102	0.85
32.6	103	0.87	107	0.92
31.4	107	0.95	112	0.99
30.1	112	1.04	117	1.09
28.6	118	1.15	124	1.20
27.0	124	1.28	130	1.34
25.3	131	1.43	137	1.50
23.7	138	1.61	144	1.69
22.2	144	1.81	151	1.89
20.6	152	2.05	160	2.16
19.1	160	2.33	168	2.44
17.7	168	2.63	176	2.77
16.5	175	2.96	184	3.11
15.4	182	3.29	191	3.44
14.5	188	3.60	197	3.78
13.9	193	3.86	203	4.05
13.5	196	4.02	205	4.20
13.4	197	4.08	206	4.27

To convert to other All up Weights the speeds V and the sinking speeds W are multiplied with the factor  $\sqrt{m/300}$ , if the figures for  $m = 300$  kg are used as a base.

To establish the McCready ring figures for a particular height, the sinking speed W must in addition be divided by the factor  $\sqrt{\rho/\rho_0}$ . This does not apply to electric variometers, as these are in general calibrated for certain height and the indication is depending on air pressure.

Height km	$\rho/\rho_0$	$\sqrt{\rho/\rho_0}$
0	1.0	1.0
0.5	0.953	0.976
1.0	0.907	0.952
2.0	0.822	0.907
3.0	0.742	0.861

Mc-Cready data for variometer calibration at 1500 m									
m =	70	80	90	100	120	140	160	180	km/h
300 kg	0	0.50	1.05	1.60	2.70	4.15	6.20	8.90	m/s
m =	75	80	90	100	120	140	160	180	km/h
330 kg	0	0.30	0.90	1.40	2.50	3.80	5.70	8.20	m/s

1 km/h = 0.540 kts = 0.621 mph

1 kg = 2.205 lbs

1 m/s = 197 ft/min = 1,94 kts

1 km = 3280 ft

Club Libelle 205

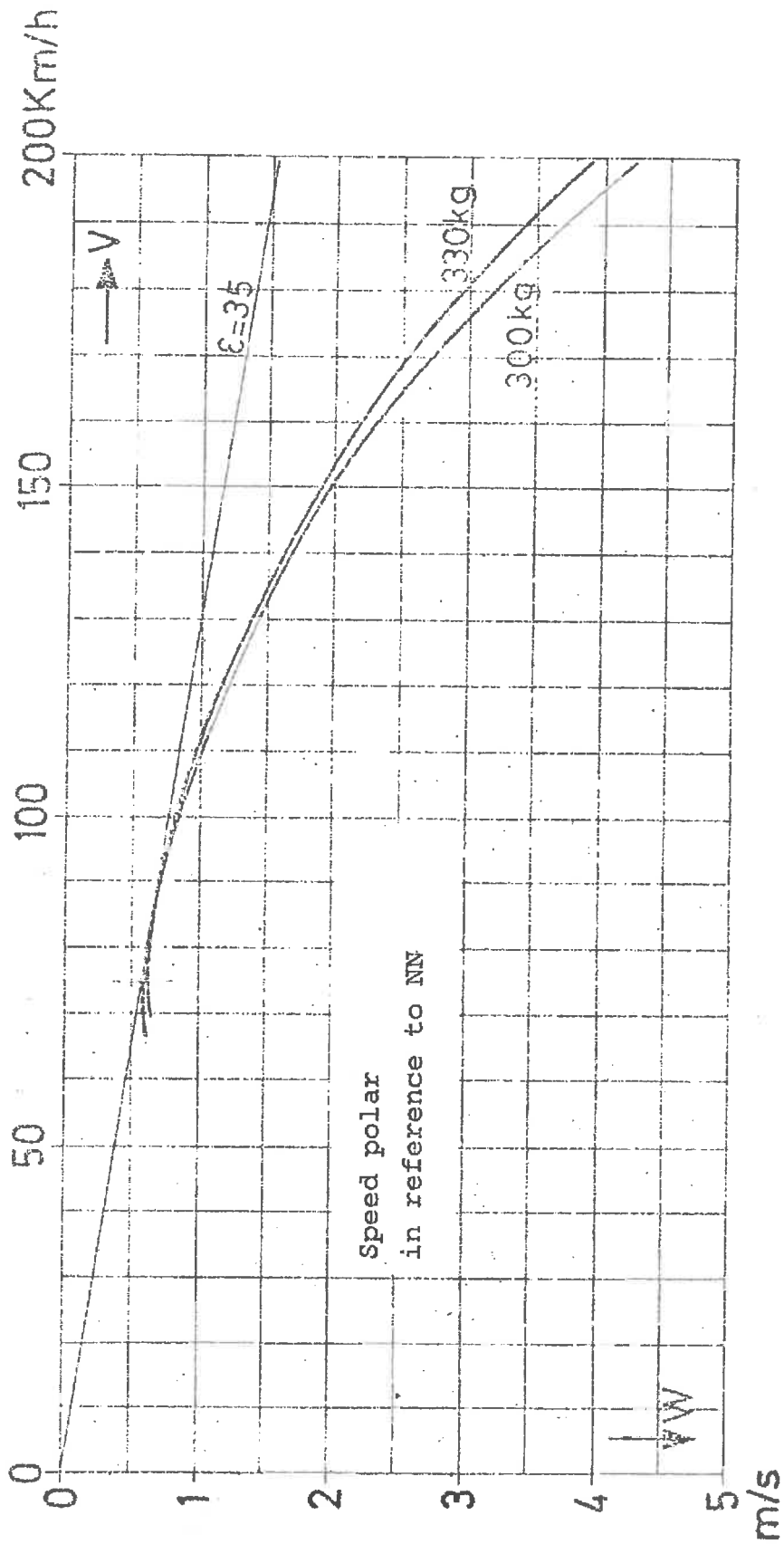

) )

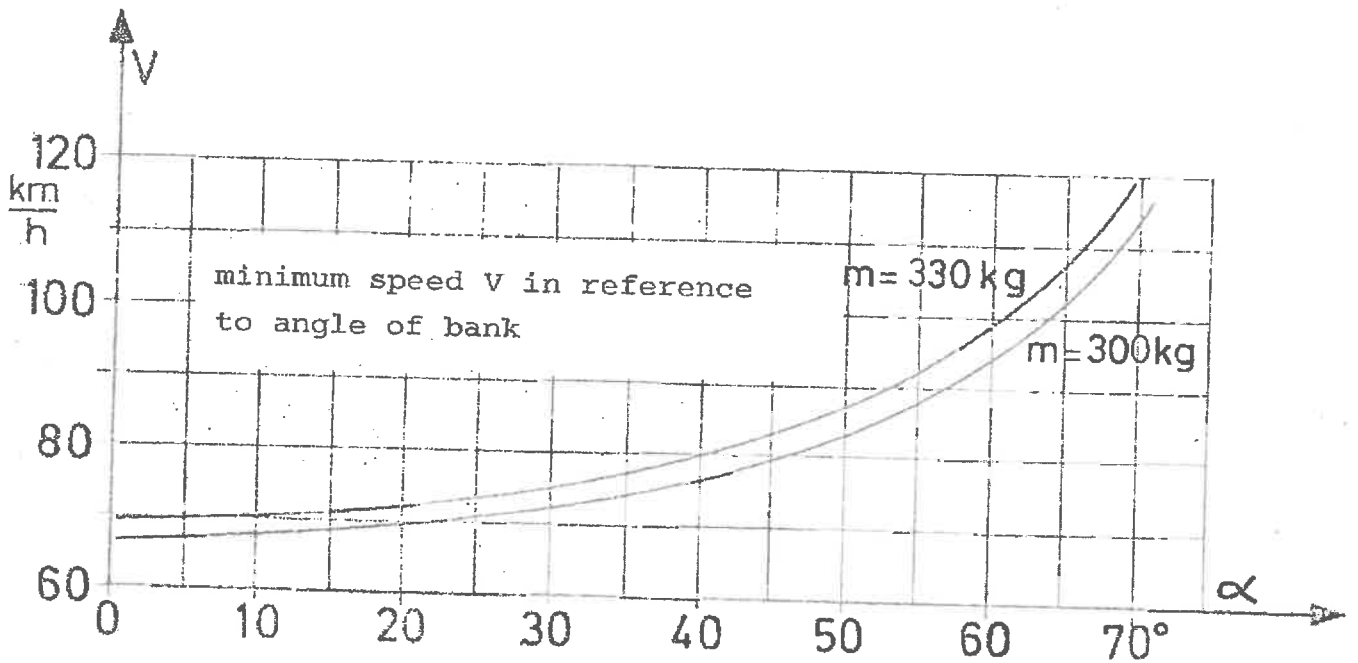
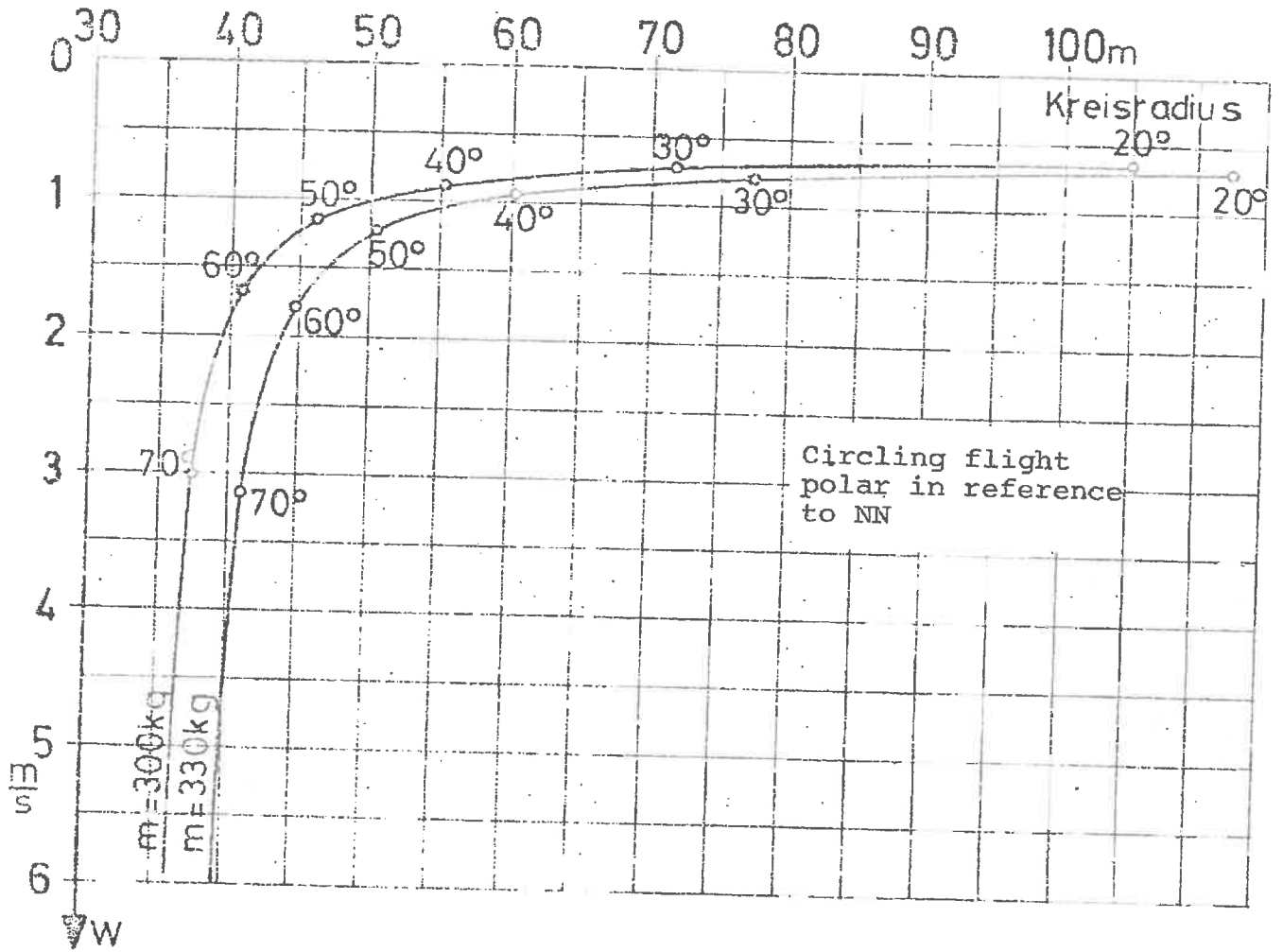

7.3 EQUIPMENT LIST:

Air Speed Indicator to TSO Specification AS 391 b  
Range up to minimum 250 km/h (135 kts)  
Colour coding according to page 14.

Altimeter to TSO specification AS 392 c

Compass. Manufacturer W. Ludolph  
Type FK 16, LBA-Geräte-Nr. L-10.410/3

Turn & Bank Indicator with slip ball to TSO Specification  
AS 395 a

VHF Transceiver LBA approved  
Weight in instrument panel max. 2 kg (4.41 lbs)

4-piece Safety Harness. Manufacturer Gadringer.  
Type BAGU Schräg IV-D, LBA Geräte-Nr. 40.070/16  
and SCHUGU II-C, LBA-Geräte-Nr. 40.071/05  
or other equivalent equipment.

## INSPECTION PROCEDURE FOR INCREASE IN SERVICE LIFE

### 1. GENERAL

The results of cyclic loading tests subsequently carried out on wing spars justify the extension of the service life of FRP Sailplanes & Motorgliders to 12000 hours, provided that the airworthiness of each individual aircraft is evidenced once more by a special multi-stage inspection program under the aspects of the service life which exceeds the normal annual inspection.

### 2. TERMS:

When the sailplane has reached a service life of 6000 hours, an inspection is to be carried out following the inspection schedule as mentioned in section 4.

If the results of this inspection are positive or after proper repair of defects observed, the service life of the sailplane is extended by 1000 hours, to a total of 7000 hours (first stage).

Once 7000 hours are reached, the inspection in accordance with the aforementioned schedule is to be repeated.

If the results are positive or after proper repair of defects observed the service life may be extended to 8000 hours (second stage).

When the sailplane has reached a service life of 8000 hours it has to be re-inspected again in compliance with the prescribed schedule. If the results are positive or when defects observed are removed, the service life may be extended to 9000 hours (third stage).

For a service life exceeding 9000 hours further regulations will be published in due time.

3. The relevant inspections are to be carried out by the service station in charge of Glasflügel sailplanes or by a certified repair station.

4. For the case that an inspection is not carried out by the service station in charge, a current inspection schedule is to be requested from the repair station in charge of Glasflügel sailplanes

Hansjörg Streifeneder  
Glasfaser-Flugzeug-Service GmbH  
DE.21G.0080 und DE.145.0100  
Hofener Weg  
D-72582 Grabenstetten  
Tel.: +49 (0)7382 1032 Fax.: +49 (0)7382 1629  
[www.streifly.de](http://www.streifly.de)

for each individual inspection.

The inspection is to be carried out not any later than three months after the inspection schedule was issued.

5. The results of the inspection are to be entered into the inspection schedule step by step.

For the case that the inspection is not carried out by the repair station in charge, a copy of the completed inspection schedule must be supplied to the repair station in charge of Glasflügel sailplanes for evaluation.

6. Obligatory periodic inspections (like the F.R.G. annual inspection according to § 15 (1) of the Luft Ger PV) are not affected by this regulation.

Suplement nr. 1 do Instrukcji  
Użytkowania w Locie  
szybowca CLUB LIBELLE 205

wyposażonego w radiostację **TQ-Systems GmbH**

**KRT2, KRT2M** Wersja 13.0

**Nr rejestracyjny: SP-4079**

**Nr fabryczny: 109**

Data: 04.08.2020

Podpis: Praskowy

**1. Spis treści:**

1. Strona tytułowa	1
2. Spis treści	2
3. Wykaz wprowadzonych zmian	3
4. Dane techniczne radiostacji	4
5. Szkic usytuowania instalacji radiostacji na szybowcu	5
6. Wykaz elementów radiostacji	5
7. Obsługa i uruchomienie radiostacji	6
8. Opis instalacji radiostacji	7
9. Montaż i demontaż radiostacji	7

**UWAGA!**

Niniejszy ZAŁĄCZNIK dotyczy wyłącznie instalowania radiostacji TQ-Systems GmbH KRT2, KRT2M na szybowcu Club Libelle 205 oraz jej uruchomienia.

Szczegółowe informacje dotyczące radiostacji zawiera „Instrukcja użytkownika i instalacji Radiostacja lotnicza VHF KRT2, KRT2M, KRT2RC

**3. Wykaz wprowadzonych zmian****UWAGA!**

Miejsca, w którym tekst uległ zmianie, jest zaznaczone pionową linią po lewej stronie tekstu oraz numerem zmiany.

Lp.	Strona	Zmiana	Data	Podpis
-----	--------	--------	------	--------

**4. Dane techniczne:**

Odbiornik umieszczony jest na tablicy przyrządów. Jest wyposażony w wyświetlacz OLED.

- zakres częstotliwości	118,00-136,00MHz
- separacja częstotliwości	8.33KHz
- moc nadajnika	6 W
- pobór prądu	2.0 A nadawanie/ 0,3A odbiór

## 5. Szkic usytuowania instalacji radiostacji na szybowcu

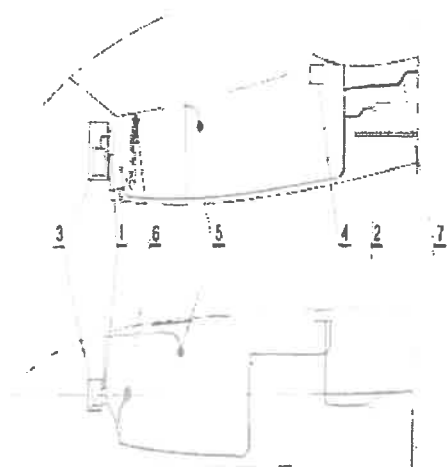

## 6. Wykaz elementów radiostacji

1. Radiostacja KRT 2
2. Zasilacz akumulatorowy 12V 4.4 – 9 Ah
3. Rozgałęźnik
4. Głośnik
5. Mikrofon
6. Przycisk „nadawanie” i przewody
7. Kabel antenowy z wtykiem koncentrycznym  
Antena z wtykiem koncentrycznym

## 7. Obsługa Radiostacji i uruchomienie radiostacji

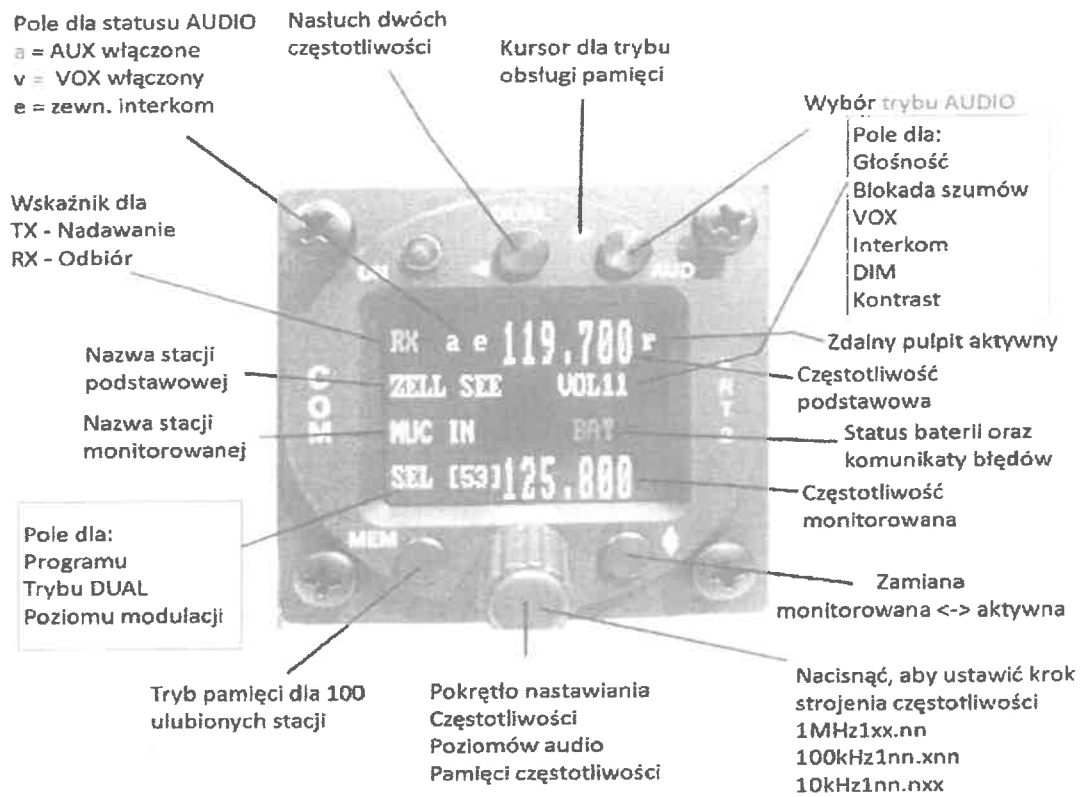

### 8. Opis instalacji radiostacji

- a) Przycisk „nadawanie” zamontowany jest na drążku sterowym na stałe. Przewód od przycisku biegnie przez kostkę przyłączeniową pod podłogą do rozgałęźnika zamocowanego na tylnej półce kabiny pilotów.
- b) Głośnik zamontowany jest za głową pilota.
- c) Antena zabudowana jest w stateczniku pionowym.
- d) Przewód antenowy przebiega od anteny przez kabinę pilota pod miską siedzeniową i jest wpięty bezpośrednio do radiostacji.
- e) Zasilanie radiostacji jest za pomocą zasilacza bateryjnego zamocowanego na podstawie z możliwością szybkiego demontażu. Zasilacz umiejscowiony jest na tylnej półce bagażnika szybowca. Przewód zasilający radiostację biegnie od rozgałęźnika pod miską siedzeniową
- f) Mikrofon zbudowany jest na prawej burcie szybowca i podłączony bezpośrednio do radiostacji.
- g) Radiostacja jest zabudowana na tablicy przyrządów

### 9. Montaż i demontaż radiostacji KRT2

Radiostację typu KRT2 należy montować na szybowcu Club Libelle 205 w oparciu o szkic usytuowania instalacji radiostacji.

1. Blok radiostacji umocowany jest na tablicy przyrządów
2. Zasilacz akumulatorowy 12V zamontowany jest na podstawie i mocowany wkrętami z podkładkami oraz nakrętkami na półce tylnego bagażnika.
3. Głośnik eliptyczny 8W w obudowie umocowany przy pomocy uchwyty na półce za głową pilota.
4. Rozgałęźnik umocowany jest blacho-wkrętami do półki tylnego bagażnika.

Mikrofon na giętkim statywie przykręcony jest za pomocą dwóch wkrętów, podkładek i nakrętek do prawej burty w kabinie pilota.

